

Precision gripper

G14 + G25 with pull down effect

G14 + G25

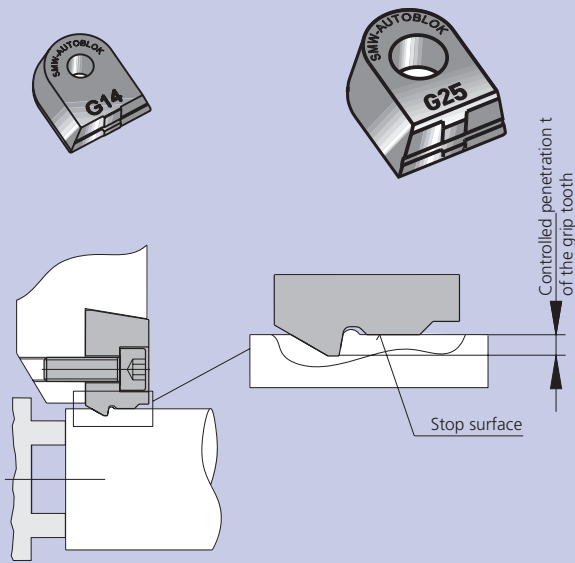

G-gripper characteristics

- Type G grippers have a stop surface for a **controlled penetration** of the grip tooth.
- **The workpiece is clamped concentric on the stop surface**, so that the clamping dia. and the machining dia. are concentric.
- The **high precision** of the gripper guarantees concentricity even after replacing worn out grippers.
- Highest torque transmission is guaranteed with the **combination of friction and positive drive**.
- The geometry of the gripper creates a **pull down effect** on the workpiece.
- **TIN coated high speed steel** for long life.
- You can **select the corresponding gripper** for all applications according to the grindstock allowance.
- Gripper with **controlled penetration** 0.070–0.30 mm are standard.
- **Special grippers are available** on request.

G14 (light duty version)

material: HSS

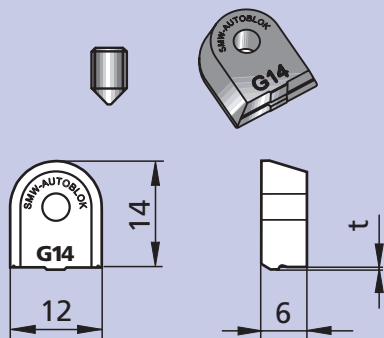

Mounting dimension

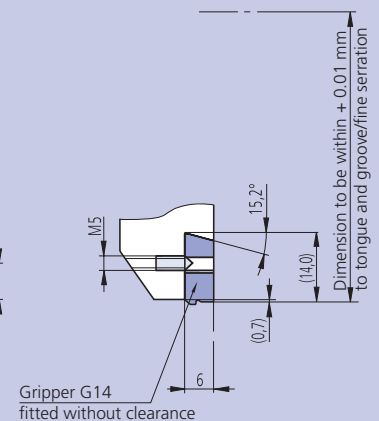
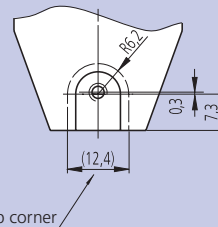
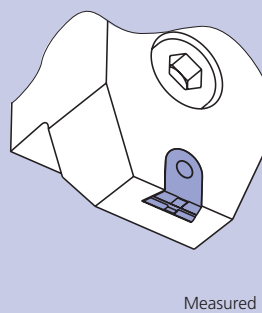

SMW-AUTOBLOK Type	G14-070	G14-100	G14-125	G14-150	G14-175	G14-200
Controlled penetration t	0.070	0.10	0.125	0.15	0.175	0.20
Id. No.	235615	235616	235617	235618	235619	235620

G25 (heavy duty version)

material: HSS

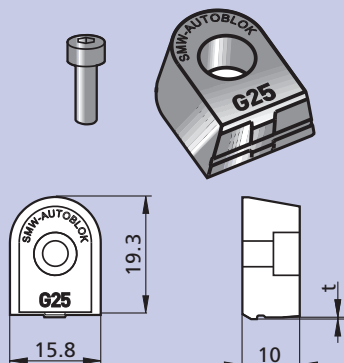

Mounting dimension

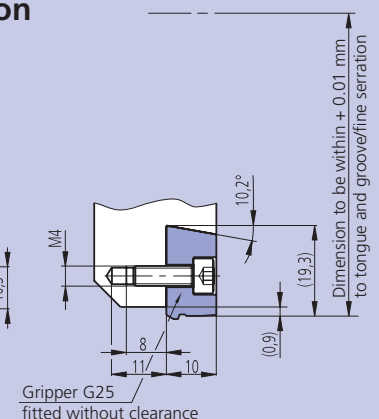
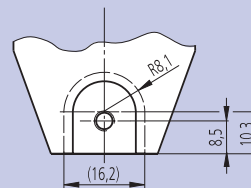
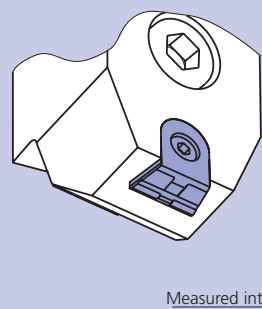

SMW-AUTOBLOK Type	G25-100	G25-150	G25-200	G25-250	G25-300
Controlled penetration t	0.10	0.15	0.20	0.25	0.30
Id. No.	232704	231275	231276	231277	231278

Precision gripper

G15 + G30 for highest torque transmission

G15 + G30

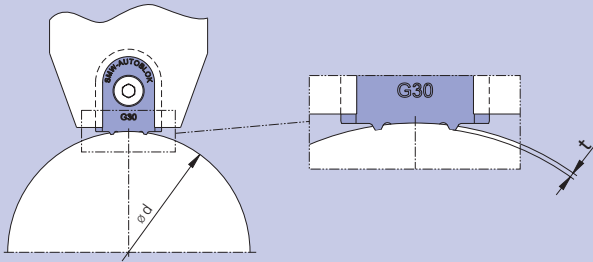

G-gripper characteristics

- Type G grippers have a stop surface for a **controlled penetration** of the grip tooth.
- **The workpiece is clamped concentric on the stop surface**, so that the clamping dia. and the machining dia. are concentric.
- The **high precision** of the gripper guarantees concentricity even after replacing worn out grippers.
- Highest torque transmission is guaranteed with the **combination of friction and positive drive**.
- **TIN coated high speed steel** for long life.
- You can **select the corresponding gripper** for all applications according to the grindstock allowance.
- Gripper with **controlled penetration** 0.15–0.30 mm are standard.
- **Special grippers are available** on request.

G15 (light duty version) material: HSS

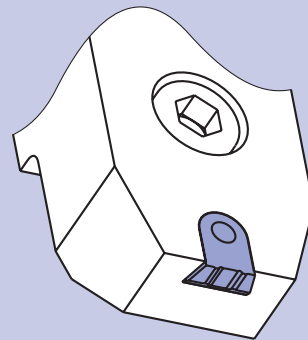
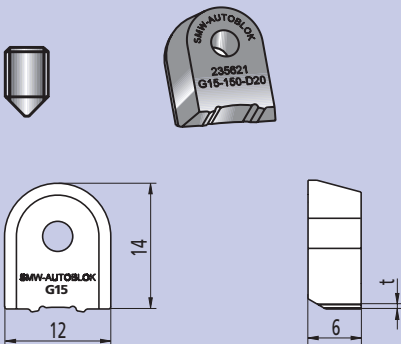

SMW-AUTOBLOK Type	G15-150	G15-200	G15-250
Work piece- \varnothing		17 - 21	
Controlled penetration t	0.15	0.20	0.25
Id. No.	235621	235622	235623
SMW-AUTOBLOK Type	G15-150	G15-200	G15-250
Work piece- \varnothing		22 - 27	
Controlled penetration t	0.15	0.20	0.25
Id. No.	237762	237763	237764
SMW-AUTOBLOK Type	G15-150	G15-200	G15-250
Work piece- \varnothing		28 - 34	
Controlled penetration t	0.15	0.20	0.25
Id. No.	235624	235625	235626
SMW-AUTOBLOK Type	G15-150	G15-200	G15-250
Work piece- \varnothing		35 - 42	
Controlled penetration t	0.15	0.20	0.25
Id. No.	237765	237766	237767
SMW-AUTOBLOK Type	G15-150	G15-200	G15-250
Work piece- \varnothing		43 - 53	
Controlled penetration t	0.15	0.20	0.25
Id. No.	235627	235628	235629
SMW-AUTOBLOK Type	G15-150	G15-200	G15-250
Work piece- \varnothing		54 - 78	
Controlled penetration t	0.15	0.20	0.25
Id. No.	237400	237401	237402
SMW-AUTOBLOK Type	G15-150	G15-200	G15-250
Work piece- \varnothing		79 - 175	
Controlled penetration t	0.15	0.20	0.25
Id. No.	237409	237410	237411

Mounting dimension

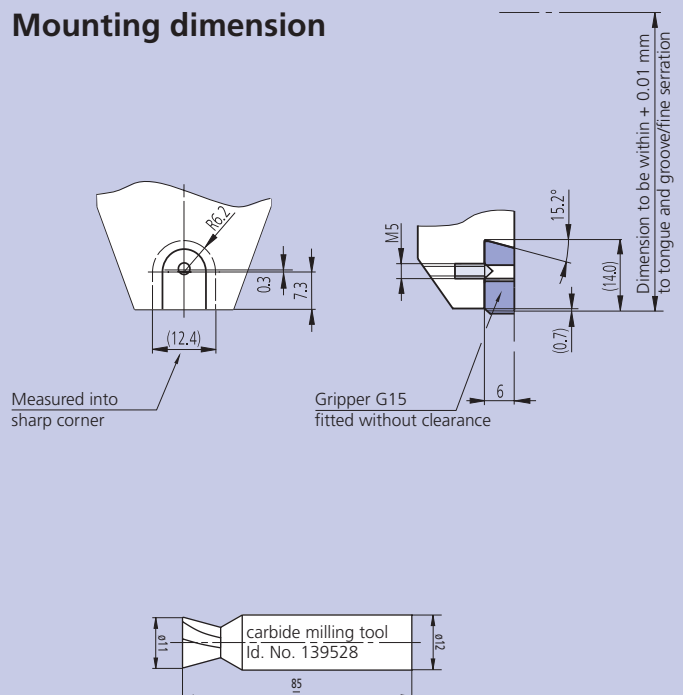

Precision gripper

G30 for highest torque transmission

G30 (heavy duty version)
material: HSS

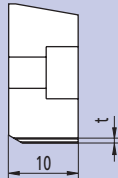
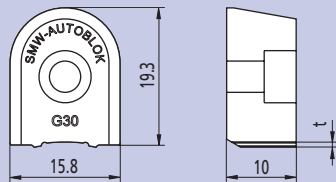
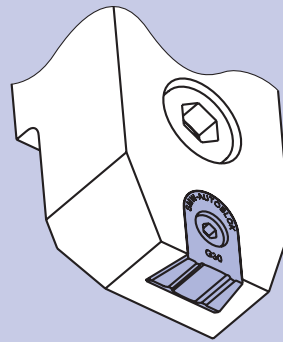
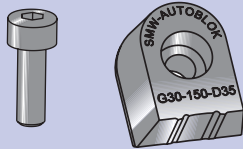

Mounting dimension

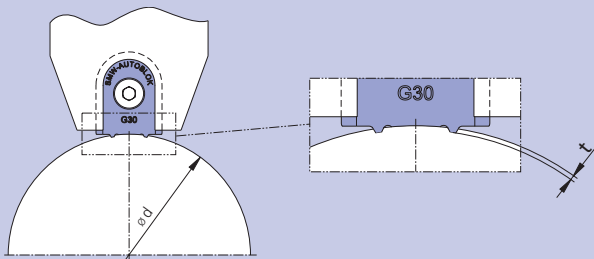

Measured into sharp corner

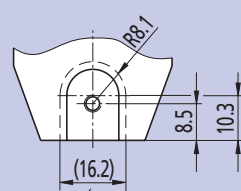

Gripper G30 fitted without clearance

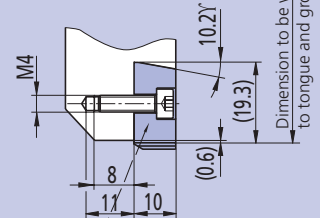

Dimension to be within +0.01 mm to tongue and groove/fine serration

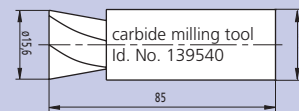

SMW-AUTOBLOK Type	G30-200	G30-250	G30-300
Work piece-Ø		24 - 32	
Controlled penetration t	0.20	0.25	0.30
Id. No.	237841	237842	237843
SMW-AUTOBLOK Type	G30-200	G30-250	G30-300
Work piece-Ø		33 - 42	
Controlled penetration t	0.20	0.25	0.30
Id. No.	233481	233482	233483
SMW-AUTOBLOK Type	G30-200	G30-250	G30-300
Work piece-Ø		43 - 52	
Controlled penetration t	0.20	0.25	0.30
Id. No.	233421	233422	233423
SMW-AUTOBLOK Type	G30-200	G30-250	G30-300
Work piece-Ø		53 - 64	
Controlled penetration t	0.20	0.25	0.30
Id. No.	233485	233486	233487
SMW-AUTOBLOK Type	G30-200	G30-250	G30-300
Work piece-Ø		65 - 84	
Controlled penetration t	0.20	0.25	0.30
Id. No.	234811	234812	234813
SMW-AUTOBLOK Type	G30-200	G30-250	G30-300
Work piece-Ø		85 - 119	
Controlled penetration t	0.20	0.25	0.30
Id. No.	237291	237292	237293
SMW-AUTOBLOK Type	G30-200	G30-250	G30-300
Work piece-Ø		120 - 174	
Controlled penetration t	0.20	0.25	0.30
Id. No.	237299	237300	237301
SMW-AUTOBLOK Type	G30-200	G30-250	G30-300
Work piece-Ø		175 - 335	
Controlled penetration t	0.20	0.25	0.30
Id. No.	237422	237423	237424